



# NEW PRODUCTS 2023

HC28

# SALVER 陶然

Design by Hanne Willmann



编号: HW03

从简约的建筑风格中获取设计灵感，横向舒展，纵向承托，以木制平台作为基准，规则排列，创造出陶然之境。和谐的平衡感，丰富的变化，精致的细节成为了设计的亮点，迎合不同的生活方式。搭配同系列异形转角组件、多功能边桌使用，轻松适用不同空间和需求。

SALVER is a platform sofa with high comfort and modularity. Due to the balanced, shape of the modules and the unique add-ons, it offers varied combinations for individual use, different room situations and lifestyles. Inspiration for the design is the slight incline of a gesture of welcome and minimalistic architecture. The smooth chamfer on the edge of the wood platform base and the soft seam from the textile cushions highlight the characteristics of the materials.

## 产品描述

沙发整体为布料或牛皮包制，底部平台与底腿为木制

## PRODUCT DESCRIPTION

Upholstered in fabric or leather. Platform base and legs are made of wood.



## 单扶 LEFT/RIGHT ONE-ARMED SOFA

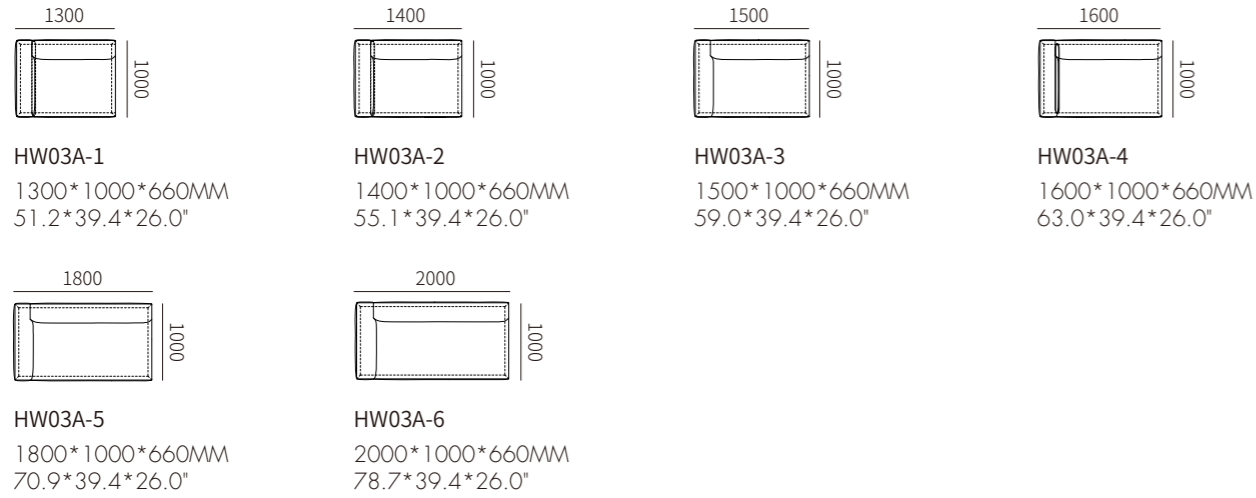

## 单背 SOFA WITHOUT ARM

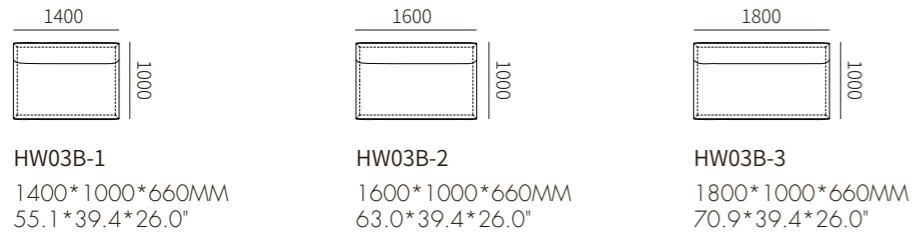

## 转角 LEFT/RIGHT CHAISE

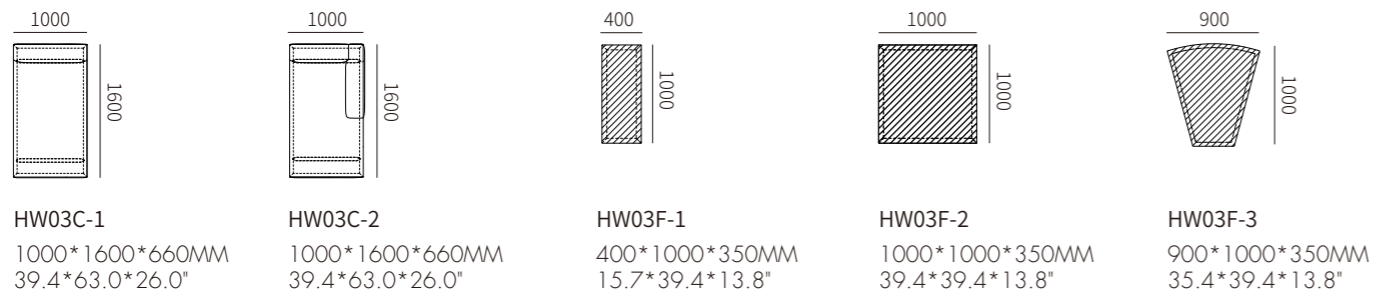

## 配套茶几 COFFEE TABLE

## 墩 MOUND

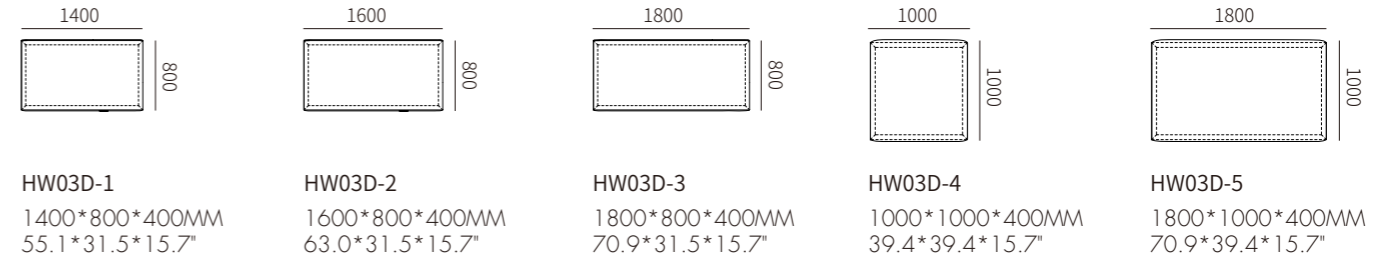

## 组合沙发 COMBINATION SOFA

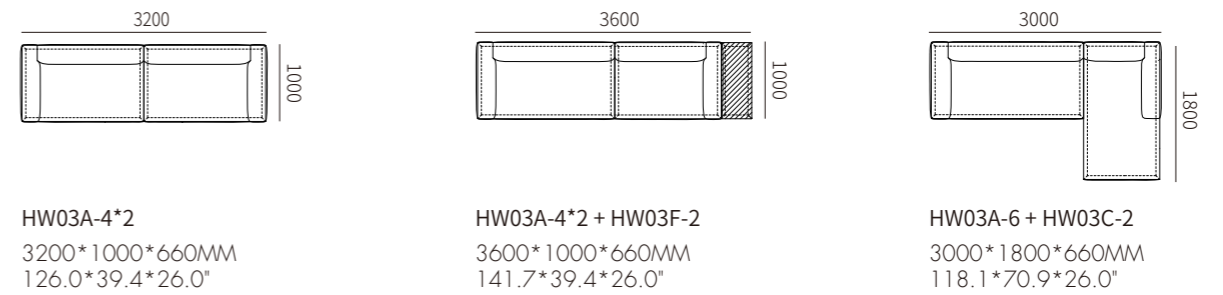

## 角位 LEFT/RIGHT CORNET SEAT

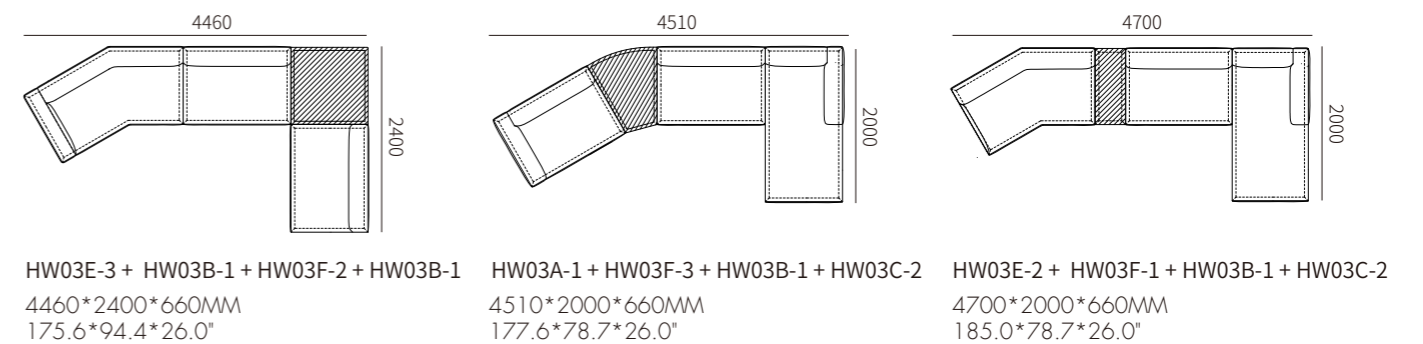
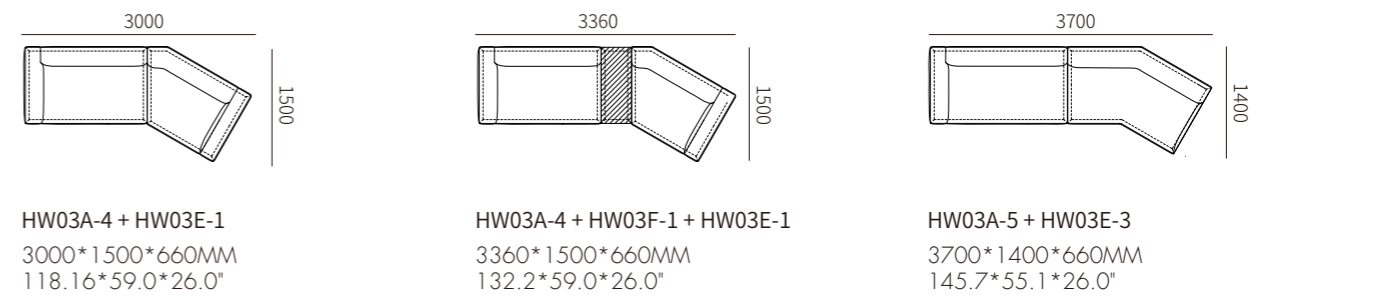
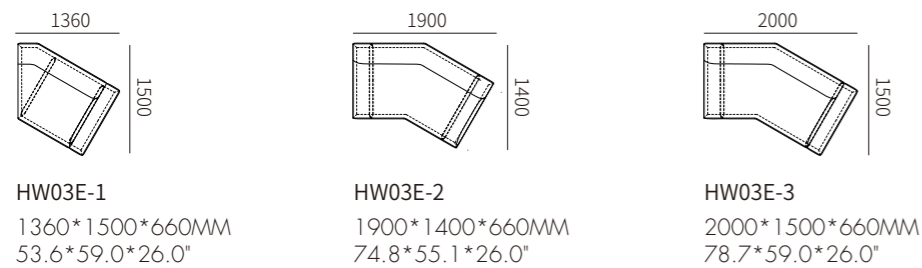



**SALVER** 陶然  
Design by Hanne Willmann





**SALVER** 陶然  
Design by Hanne Willmann

# MEG 宾至

Design by Christophe Delcourt



编号: G83

这是一件力量与优雅碰撞的设计作品。MEG宾至宽大的坐席，轻仰的角度，为入座带来舒适体验。硬朗的木质扶手环抱着座椅，三足鼎立的腿部结构为椅子增添了庄重感。现代设计与传统绅士礼仪的完美结合让宾至座椅系列为空间带来复古与现代的氛围。

Designer Christophe created a classically designed armchair with a modern appeal to last for generations. The wood frame with the clear silhouette and the three-legged structure add a sense of formality and etiquette to the chair. MEG chair resonates with a sense of modernism and tradition.

## 产品描述

软包整体为布料或牛皮包制，扶手、底框为木制开孔漆或烤漆

## PRODUCT DESCRIPTION

The armchair is upholstered in fabric or leather. Arms, legs and frames are made of wood, available in natural finish or colored lacquer finish.

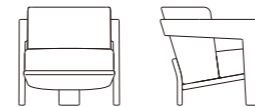

G83

740\*760\*720MM  
29.1\*29.9\*28.3"





**MEG** 宾至  
Design by Christophe Delcourt



# MEG 宾至

Design by Christophe Delcourt



编号: G82

MEG宾至扶手椅同系列餐椅，宽大的坐席，轻仰的角度，为入座带来舒适体验。硬朗的木质扶手环抱着座椅，三足鼎立的腿部结构为椅子增添了庄重感。现代设计与传统绅士礼仪的完美结合让宾至座椅系列为空间带来复古与现代的氛围。

Designer Christophe created a classically designed dining chair with a modern appeal to last for generations. The wood frame with the clear silhouette and the three-legged structure add a sense of formality and etiquette to the chair. MEG chair resonates with a sense of modernism and tradition.

## 产品描述

软包整体为布料或牛皮包制，扶手、底框为木制开孔漆或烤漆

## PRODUCT DESCRIPTION

The armchair is upholstered in fabric or leather. Arms, legs and frames are made of wood, available in natural finish or colored lacquer finish.

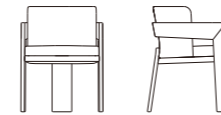

G82

580\*600\*750MM  
22.8\*23.6\*29.5"



**MEG** 宾至 餐椅  
Design by Christophe Delcourt



# MEMORY 竹屿

Design by Dainelli Studio



编号: DA03

竹屿餐椅，是珍贵纯粹的手工之作。从天然朴素的材质中培育出细腻感性的美感。因取之于自然，工匠又以无私潜心的态度制作，令人珍视的同时也在思考物尽其用的生活智慧。从扶手的转弯到腿部都完整表现着实木雕琢后的细致纤薄感，MEMORY竹屿连接着人与自然，带出潜藏其中的质感与魅力。

The inspiration came from the past. The truly thin structure brings an elegant lightness to a sturdy, precious handcrafted chair. From the back to the arm, it forms beautiful curves in three dimensions. The craftsman's dedication makes MEMORY chair a precious piece to be treasured, and to contemplate the wisdom of life in value and treasure everything around.

## 产品描述

餐椅整体为实木，坐垫软包为布料或牛皮包制

## PRODUCT DESCRIPTION

Dining chair is made of wood, seat cushion upholstered in fabric or leather.

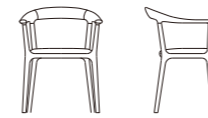

DA03

600\*520\*765MM  
23.6\*20.5\*30.1"



**MEMORY** 竹屿  
Design by Dainelli Studio



# KAT 璞玉

Design by Christophe Delcourt



编号: G81

璞玉餐椅以简洁利落的造型体现出传统与现代完美融合的特色。浑圆略带钝感的设计就像璞玉，在桌旁散发着内敛迷人的气质。以实木为基础，仿旧镀铜工艺作为装饰，试图内敛锋芒却在不经意间吸引目光。

KAT dining chair is a well-crafted and utilitarian design. The round edges and corners on the solid wood leg contribute a soft and quiet feel. The visible brushed brass screws and rails add a touch of elegance. It's a chair that does not call for attention but attracts you anyway.

## 产品描述

餐椅椅腿为实木，椅腿间横秤以黑灰氟碳漆金属条衔接装饰。坐垫与靠背软包为布料或牛皮包制，椅背同样有黑灰氟碳漆金属装饰扣。

## PRODUCT DESCRIPTION

Dining chair frame is made of wood, seat cushion and back cushion upholstered in fabric or leather. Metal rails between the leg, and accent screws on the back are finished in dark grey epoxy finish.



G81

520\*500\*800MM  
20.5\*19.7\*31.5"



# ALYA 依兰

Design by LualdiMeraldi studio



编号: M02/M03

ALYA依兰扶手椅以其柔和而华丽的外形脱颖而出。它采用全软垫设计，营造出一种优雅的包覆感。软垫适应扶手椅的形状，勾勒出蜿蜒诱人的曲线。靠背内侧有流动的波纹，为整体设计增添了一丝活力和动感。

The ALYA armchair is a product that stands out for its soft and flashy shapes. It is fully upholstered, creating an elegant and enveloping look. The upholstery adapts to the shape of the armchair, outlining its sinuous and inviting curves. The inner part of the backrest features flowing waves, lending a touch of dynamism and movement to the overall design.

## 产品描述

扶手椅整体为布料或牛皮包制, 底座可转  
搭配同款脚塌, 脚踏不可转

## PRODUCT DESCRIPTION

The swivel armchair is upholstered in fabric or leather. The footstool is upholstered in fabric or leather.



M02/M03

860\*800\*720MM  
33.9\*31.5\*28.3"



# ROMA 间筑

Design by Dainelli Studio



## 产品描述

茶几边几整体为木制烤漆，颜色可选

## PRODUCT DESCRIPTION

Coffee table are made of wood in colored lacquer finish.



DA02

1200\*1200\*300MM  
47.2\*47.2\*211.8"

编号：DA02

间筑的灵感来自罗马的方形斗兽场，那弧形的窗户和方形的建筑浑然一体，以这两个气质完全不同的形状结合出新的力量作为概念缘起。间筑茶几系列一套三组，以润泽烤漆，浑厚造型呈现着建筑之美。

Inspired to square colosseum in Rome, were the arc shape of windows and the straight square shape of building live together. ROMA coffee table collection comes in a set of three, with sturdy shapes that capture the beauty of architecture.

# ROMA 间筑

Design by Dainelli Studio



编号：DA03

间筑的灵感来自罗马的方形斗兽场，那弧形的窗户和方形的建筑浑然一体，以这两个气质完全不同的形状结合出新的力量作为概念缘起。间筑茶几系列一套三组，以润泽烤漆，浑厚造型呈现着建筑之美。

Inspired to square colosseum in Rome, were the arc shape of windows and the straight square shape of building live together. ROMA coffee table collection comes in a set of three, with sturdy shapes that capture the beauty of architecture.

## 产品描述

茶几边几整体为木制烤漆，颜色可选

## PRODUCT DESCRIPTION

Coffee table are made of wood in colored lacquer finish.



DA03

450\*450\*450MM  
17.7\*17.7\*17.7"



# ROMA 间筑

Design by Dainelli Studio



编号: DA04

间筑的灵感来自罗马的方形斗兽场，那弧形的窗户和方形的建筑浑然一体，以这两个气质完全不同的形状结合出新的力量作为概念缘起。间筑茶几系列一套三组，以润泽烤漆，浑厚造型呈现着建筑之美。

Inspired to square colosseum in Rome, were the arc shape of windows and the straight square shape of building live together. ROMA coffee table collection comes in a set of three, with sturdy shapes that capture the beauty of architecture.

## 产品描述

茶几边几整体为木制烤漆，颜色可选

## PRODUCT DESCRIPTION

Coffee table are made of wood in colored lacquer finish.



DA04

350\*350\*480MM  
13.8\*13.8\*18.5"

# ANNETT 玉柱

Design by René Chyba



编号: J29

纯粹、简约的几何线条是新款餐桌 ANNETT 的特点，展现了卓越的精湛工艺。柱形桌腿极具特色，匀称而有力，与桌面形成和谐的比例感，衔接处的金属镶边细节是点睛之笔。ANNETT餐桌凭借其永恒的优雅，可以理想地融入各种风格的餐厅空间。

Characteristic are the round corner table legs, which create a beautiful silhouette in a balanced interaction with the harmonious proportions of the table top. The pure, minimalist, geometric lines characterize the new dining table ANNETT showcasing excellent, outstanding craftsmanship. With its timeless elegance, it can be ideally integrated into interiors in a wide variety of styles.

## 产品描述

餐桌整体为实木，桌面可选木制或岩板。金属装饰部分为镀铜拉丝金属

## PRODUCT DESCRIPTION

Dining table are made of wood with table top in wood or sintered stone. Decorated with metal in brushed brass finish.

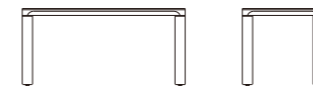

J29

1600\*800\*750MM  
63.0\*31.5\*29.5"

1800\*950\*750MM  
70.9\*37.4\*29.5"

2000\*950\*750MM  
78.7\*37.4\*29.5"

2200\*1050\*750MM  
86.6\*41.3\*29.5"

2400\*1050\*750MM  
94.4\*41.3\*29.5"



# JOUI 竹栖

Design by Studio Cemoi



## 产品描述

餐边柜整体为木制，柜台面为岩板

## PRODUCT DESCRIPTION

Cabinet is made of wood with top in sintered stone.

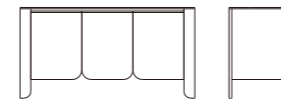

### FE01

1540\*500\*800MM  
60.6\*15.7\*31.5"

1800\*500\*800MM  
70.9\*15.7\*31.5"

2000\*500\*800MM  
78.7\*15.7\*31.5"

编号：FE01

JOUI边柜的灵感来源于中国古典旗袍中“如意领”元素，心之所向皆能如愿抵达的美好故事，是文化也是期许。台面以温润的白色石材覆盖，轻微圆角设计将东方文化折衷且圆融的情感一一讲述。柜脚则取如意领口的轻盈，也像舞者踮起脚尖，生活中便多了一份蜻蜓点水的活泼与愉悦。

JOUI sideboard is inspired by the "Ruyi Collar" element of the classical Chinese cheongsam, a beautiful representative of "wish your dream come true". The graceful, soft curves on the legs and corners share the wisdom of life. The lightness of the feet captures the dancers' tiptoe. Together, the JOUI sideboard brings the sweet message and the eastern culture into life.

# JOM 南屏

Design by Christophe Delcourt



编号: G84

优美的南屏是以唐朝的屏风概念创作的床头设计，四扇的屏风式床头带来了高贵的气质，美学的内涵，同时也创造了卧室空间私密包围感的效果。木制的框架带来坚固的结构与支撑，结合软包的处理达到利落却不失舒适的效果。

The JOM bed was created with the concept of the coromandel screen from the Tang Dynasty. It captures the traditional style of art and aesthetic while inheriting the function of sheltering, partition, and decoration. The fully upholstered bed creates a cozy feeling.

## 产品描述

茶床整体为布料或牛皮包制，底腿为黑灰氟碳漆

## PRODUCT DESCRIPTION

Bed upholstered in fabric or leather, bottom metal feet are in dark grey epoxy finish.

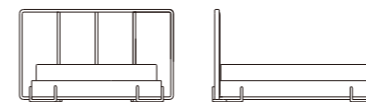

G84

2030\*2200\*1240MM  
79.9\*86.6\*48.8"

2230\*2200\*1240MM  
87.8\*86.6\*48.8"

2430\*2200\*1240MM  
95.7\*86.6\*48.8"

